

* Introduction

The communication branch is the oldest branch of the electronics field. Telecommunication means communicating at a distance. A communication system is the means of conveying the information from one place to the other. This information can be of different types such as sound, picture, music, computer data etc.

The field of communication engineering started developing rapidly in the nineteenth century when the telegraph, telephone and then the radio wave invented. The development was still faster in the twentieth century when first black and white and then colour TVs were brought in use. Then came the age of satellite communication, cable TV, mobile telephones etc.

* Basic Communication System

The block diagram of the simplest basic communication system is as shown in below Fig. 1.

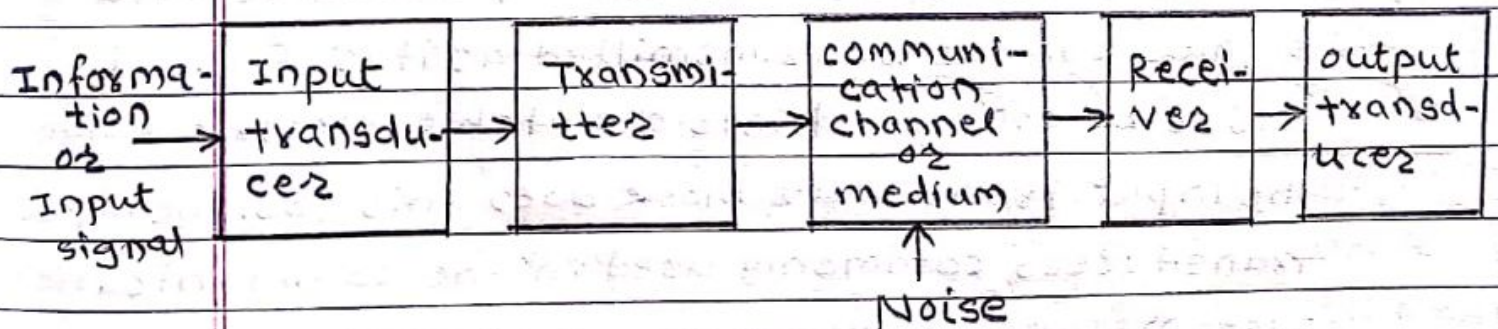

Fig 1 Block diagram of Basic Communication system

From the above Fig. 1, the basic elements of a communication system are, transmitter, a communication medium and the receiver. When the transmitted signal is travelling from the transmitter to the receiver, noise gets added to it. The elements of basic communication system are as follows:

1. Information or input signal
2. Input transducer
3. Transmitter
4. communication channel or medium
5. Noise
6. Receiver
7. output transducer

1. Information or Input signal

The information can be in the form of a sound signal like speech or music or it can be in the form of pictures (TV signals) or it can be data information coming from a computer.

2. Input transducer

The information in the form of sound or data signals cannot be transmitted as it is. First it has to be converted into a suitable electrical signal. The input transducer block does this job. The input transducers commonly used in the communication systems are microphones, TV cameras etc.

3. Transmitter

The function of the transmitter block is to convert the electrical information to a suitable form. In addition to that it increases the power level of the signal. The power level should be increased in order to cover a large range. The transmitter consists of the electronic circuits such as amplifier, mixer, oscillator and power amplifier.

4. Communication channel or medium

The communication channel is the medium used for transmission of electronic signal from one place to the other. The communication medium can be conducting wires, cables, optical fiber or free space. Depending on the type of communication medium, two types of communication systems will exist. They are:

- (a) wire communication or line communication
- (b) wireless communication or radio communication

5. Noise

Noise is unwanted electrical signal which gets added to the transmitted signal when it is travelling towards the receiver. Due to the noise, the quality of the transmitted information will degrade. The noise cannot be separated out from the information. Hence, noise is a big problem in the communication systems. The noise is either man made

or natural. The sources of natural noise are lightning or radiation from the sun and stars etc. The man made noise are the noise produced by electrical ignition systems of the automobiles, welding machines, electric motors etc. Though the noise can not be completely eliminated but its effect can be reduced by using various techniques.

6. Receiver

The received signal is amplified, demodulated and converted into a suitable form. The receiver consists of electronic circuits like mixer, oscillator, detector, amplifier etc.

7. Output Transducer

The output transducers converts the electrical signal at the output of the receiver back to the original form i.e. sound or T.V. pictures etc. The typical examples of the output transducers are loud speakers, picture tubes, computer monitor etc.

* Classification based on the Technique of Signal Transmission

Based on the technique used for the signal transmission, the electronic communication systems are categorized as

1. Baseband transmission systems
2. communication systems using modulation

1. Baseband Signals and Baseband Transmission

The information of the input signal to a communication system can be analog i.e. sound, picture or it can be digital eg. the computer data. The electrical equivalent of this original information signal is known as the baseband signal.

In the baseband transmission system, the baseband signals (original information signals) are directly transmitted. Examples of these type of systems are telephone networks where the sound signal converted into the electrical signal is placed directly on the telephone lines for transmission. Another example of baseband transmission is computer data transmission over the coaxial cables in the computer networks. Thus the baseband transmission is the transmission of the original information signal as it is.

The baseband transmission cannot be used for the radio transmission where the medium is

free space.

2. Communication System using Modulation

In the modulation process, the baseband signal is called "modulating signal" and another higher frequency signal is called as the "carrier". The carrier signal will carry the modulating signal to the destination.

The carrier is usually a sinewave signal at higher frequency than the information signal (baseband signal). The baseband signal will modify the amplitude or frequency or phase of the carrier in the process of modulation. Depending on which parameter of the carrier is changed the modulation techniques are classified as follows:

(i) Amplitude Modulation [AM]

Amplitude of the carrier is varied keeping its frequency and phase constant.

(ii) Frequency Modulation [FM]

Frequency of the carrier is varied keeping its amplitude and phase constant.

(iii) Phase Modulation [PM]

Phase of the carrier is modified, keeping the other two parameters constant.

* Need of Modulation in Communication System

In the process of modulation, the baseband signal is translated i.e. shifted from low frequency to high frequency. This frequency shift is proportional to the frequency of carrier. The modulation process has the following advantages:

1. Reduction in the height of antenna
2. Avoids mixing of signals
3. Increases the range of communication
4. Multiplexing is possible
5. Improves quality of reception.

* AM Receiver

The function that ~~must~~ a receiver must perform in order to receive the wanted signal are as follows:

1. select the desired signal from all the other unwanted signals.
2. Amplify the desired signal.
3. Demodulate the amplified signal.
4. After demodulation, the original modulating signal is obtained which must be amplified.
5. Apply the ~~demo~~ amplified demodulated signal to the loudspeaker.

There are only two types of receivers -

- <I> The tuned radio frequency (TRF) receiver
- <II> The superheterodyne receiver.

(I) Tuned Radio Frequency (TRF) Receiver

The virtues of TRF receiver are its simplicity and high sensitivity. The block diagram of the TRF receiver is as shown in below Fig. 1.

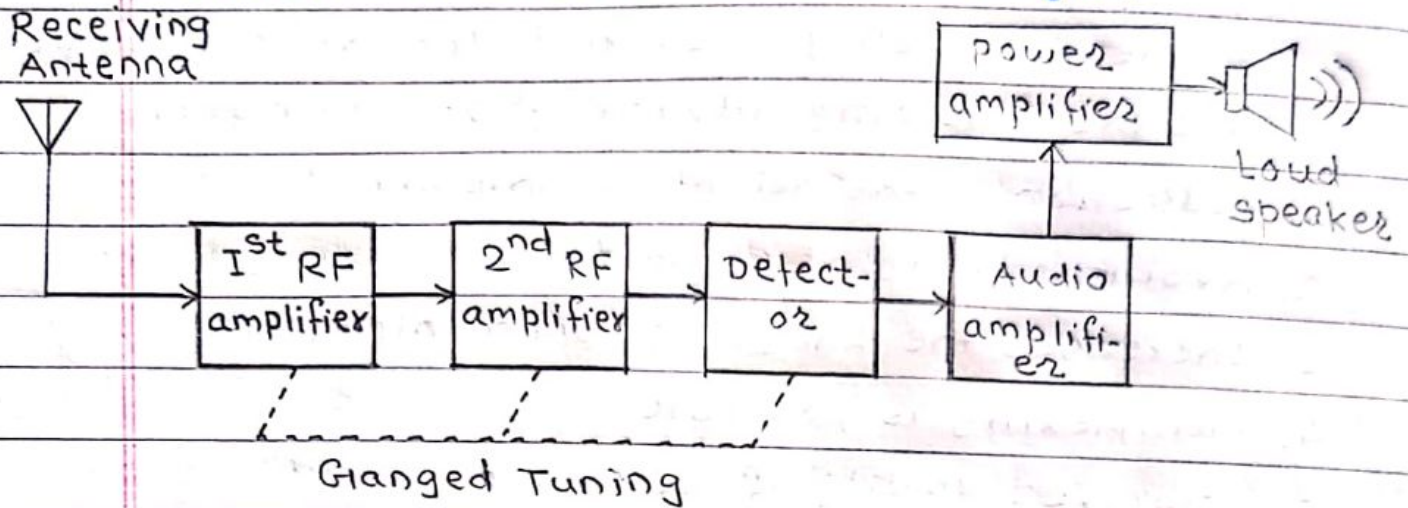

Fig 1 The TRF Receiver

The TRF receiver consists of two or three "tunable" RF amplifiers. All these amplifiers are tuned simultaneously to the desired signal frequency. A detector, AF amplifier and power amplifier follow the tuned RF amplifiers.

Operation:

The AM transmission takes place in the medium wave (MW) band or in the short wave (SW) band. The frequency range for the MW band is from 530 kHz to 1640 kHz. Different radio stations operate at different frequencies in this range of frequency. e.g. the Pune station operates at a frequency of 800 kHz. The operation of the TRF receiver is as below-

(i) Due to the electromagnetic waves passing over the receiving antenna, voltage is induced in it. This

induced signal consists of signals from various transmitting stations.

(ii) The RF amplifiers are tuned simultaneously to select and amplify the desired signal and reject all the other signals. Tuning means we adjust the resonant frequency of the tuned circuits equal to the desired frequency. Ganged tuning means simultaneous tuning of tuned circuits in all the RF amplifier stages using a gang capacitor.

(iii) The amplified signal is then demodulated (detected) by the detector. The carrier signal is bypassed and only the modulating signal is recovered in this process.

(iv) The detected signal is amplified to the adequate power level using the audio amplifier and power amplifier and given to the loudspeakers for reproduction.

→ Problems in the TRF Receiver

Though the TRF receivers are simple in operation, this receiver has some serious problems. They are:

- (1) Instability
- (2) Variation in the bandwidth over the tuning range
- (3) Insufficient selectivity at high frequencies, and poor adjacent channel rejection.

<1> Instability

The overall gain of the RF amplifier stages is very very high. So a very small feedback signal from its output to input with correct phase (+ve feedback) can initiate oscillations in the RF amplifier stage. e.g. if the gain is 40,000 then to make the " $A\beta$ " product < 1 , the required feedback signal is only $1/40,000$ of the output. This feedback takes place through the stray capacitances in the circuit. The reactance of C decreases at higher frequencies which results in the increased feedback. Thus the possibility of oscillatory behaviour and therefore instability will increase with increased frequency. Once the oscillations begin, the RF amplifiers cannot amplify the desired signal.

<2> Variation in the bandwidth (BW)

When the receiver is tuned, it is tuned to the carrier frequency (f_c), and the tuned circuit is expected to select the carrier and the sidebands of the desired signal. That means it must have adequate bandwidth (BW). For a tuned circuit

$$BW = \frac{f_2}{Q}$$

where f_2 is the resonant frequency which is f_c and Q is the quality factor. Let us assume that the required BW = 10 kHz. This will remain constant

at all the carrier frequencies. Now at $f_2 = f_c = 535$ kHz the Q of the tuned circuit is

$$Q = \frac{535}{10} = 53.5$$

Now if $f_2 = f_c = 1640$ kHz at the same bandwidth of 10 kHz the required value of Q will be

$$Q = \frac{1640}{10} = 164$$

This value of Q is practically unobtainable due to various losses taking place at high frequency. At the most we can obtain a Q of 120 at this frequency. Now the corresponding bandwidth will be

$$\begin{aligned} BW &= \frac{f_2}{Q} \\ &= \frac{1640 \text{ kHz}}{120} = 13.7 \text{ kHz} \end{aligned}$$

The required BW is 10 kHz. Due to increased bandwidth the receiver will pick the adjacent channel along with the desired one.

<3> Insufficient selectivity

Due to increased BW at higher frequencies the ability of the TRF receiver to select the desired signal and reject all others is seriously affected. This is called loss of selectivity.

Due to these problems of instability and poor adjacent channel rejection, the TRF receivers are

not used. They are replaced by the superheterodyne receivers.

<II> Superheterodyne Receivers

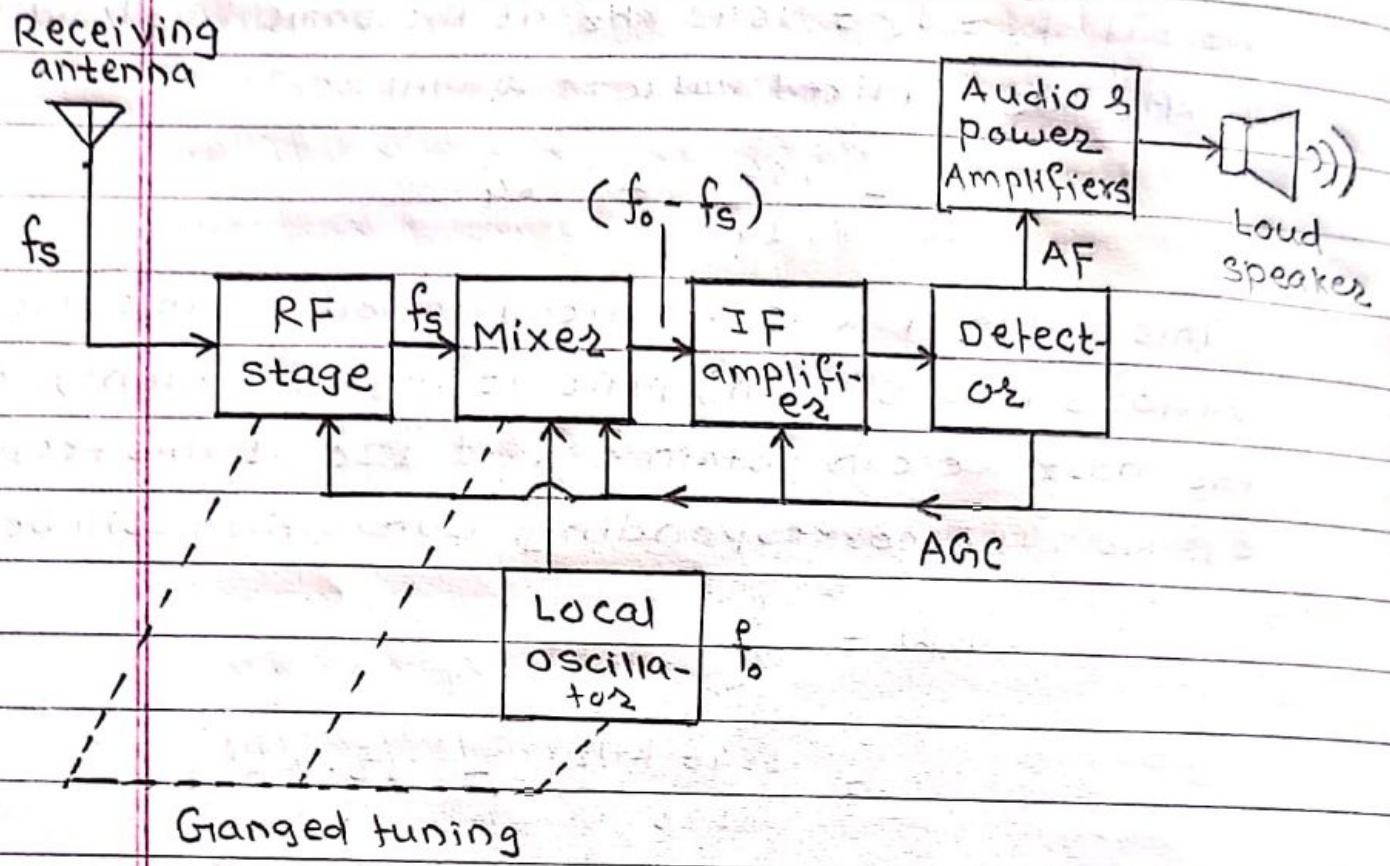

Fig 1. The superheterodyne Receiver

The problems in the TRF receiver are solved in superheterodyne receivers by converting every selected RF signal to a fixed lower frequency called as the "intermediate frequency (IF)". This frequency contains the same modulation as the original carrier. The IF signal is amplified and detected to get back the modulating signal. As the IF is lower than the lowest RF signal frequency, the possibility of osc

Distortions and instability is minimized. Also the required value of Q for constant BW does not depend on the frequency of desired signal, because the "IF" is constant and same for all the incoming RF signals. Thus the super-heterodyne receiver solves all the problems associated with the TRF receiver.

The block diagram of superheterodyne receiver is shown in above Fig. 1.

Operation

- (i) The RF amplifier is used to select the wanted signals, reject all other signals and reduce effect of noise we get the signal of frequency f_s at the output of RF amplifier.
- (ii) The mixer receives signals from RF amplifier (f_s) and local oscillator (f_o). These signals are mixed together to produce the intermediate frequency (IF).

$$\text{Frequency of IF} = (f_o - f_s)$$

In order to maintain a constant difference between the local oscillator and incoming frequency, ganged tuning is used. This is simultaneous tuning of RF amplifier, mixer, local oscillator and it is achieved by using ganged tuning capacitors.

- (iii) The intermediate frequency signal is then amplified by one or more IF amplifier stages. This provides most of the gain (and hence sensitivity) and the bandwidth requirement of the receiver. Therefore the sensi-

vity and selectivity of this receiver is good.

- (iv) The amplified IF signal is detected by the detector to recover the original modulating signal. This is then amplified and applied to the loudspeaker.
- (v) AGC means automatic gain control. This circuit controls the gains of the RF and IF amplifiers to maintain a constant output voltage level even when the signal level at receiver input is fluctuating.

~~* Characteristics~~

* Characteristics of the Radio Receivers

The important characteristics of the radio receiver are

- (i) sensitivity
- (ii) selectivity
- (iii) Fidelity

These characteristics are useful to judge the performance of a radio receiver. These characteristics are measured under the standard operating conditions.

<I> Sensitivity

Sensitivity of a radio receiver is defined as its ability to amplify weak signals. It is often defined in terms of the input voltage that must be applied at the input of the receiver to obtain a

standard output power. sensitivity is measured in μV or decibels, below 1V .

The below Fig. 1 shows the typical sensitivity curve of a receiver. It shows the variation of sensitivity over the medium wave (MW) band of frequencies.

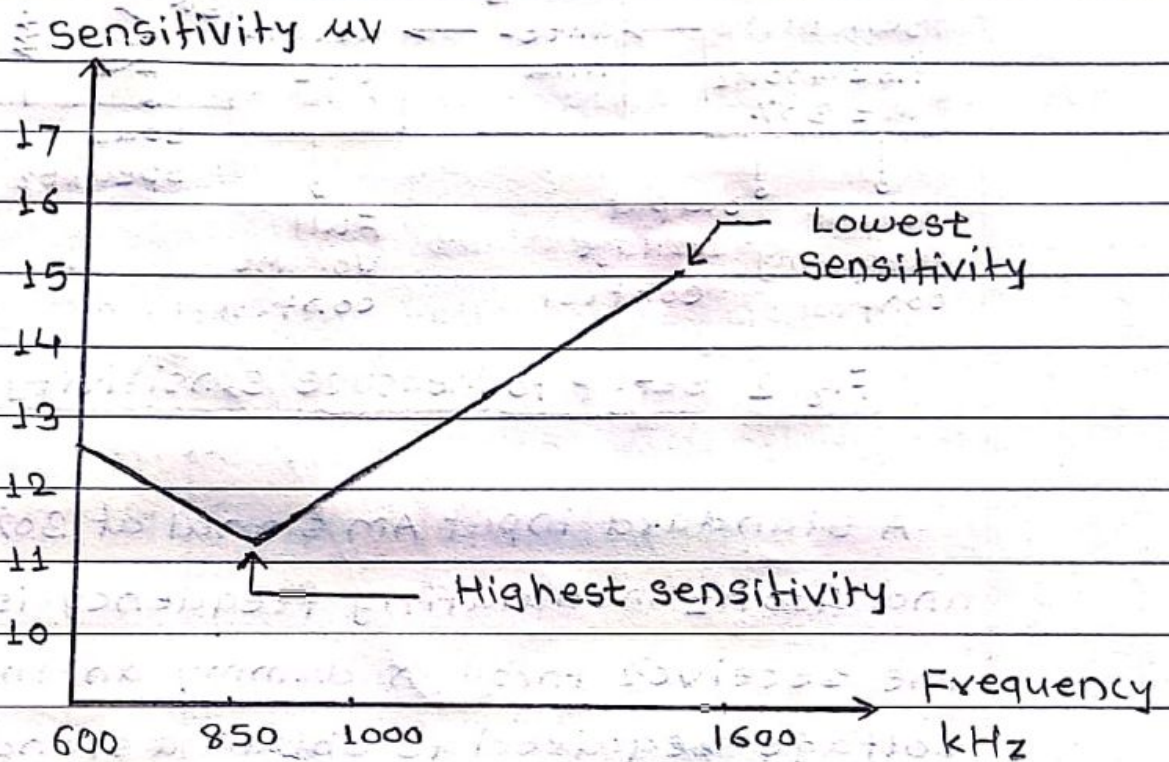

Fig. 1: Sensitivity curve

From the curve it is evident that the radio receiver is the most sensitive at about 850 kHz. The sensitivity of the receiver is decided by the gain of RF and IF amplifiers.

Sensitivity Measurement

The sensitivity measurement is carried out under standard test conditions. The AM signal is applied to the receiver through a standard coupling network

known as "dummy antenna". The output power is measured by replacing the loudspeaker by an equal value load resistance.

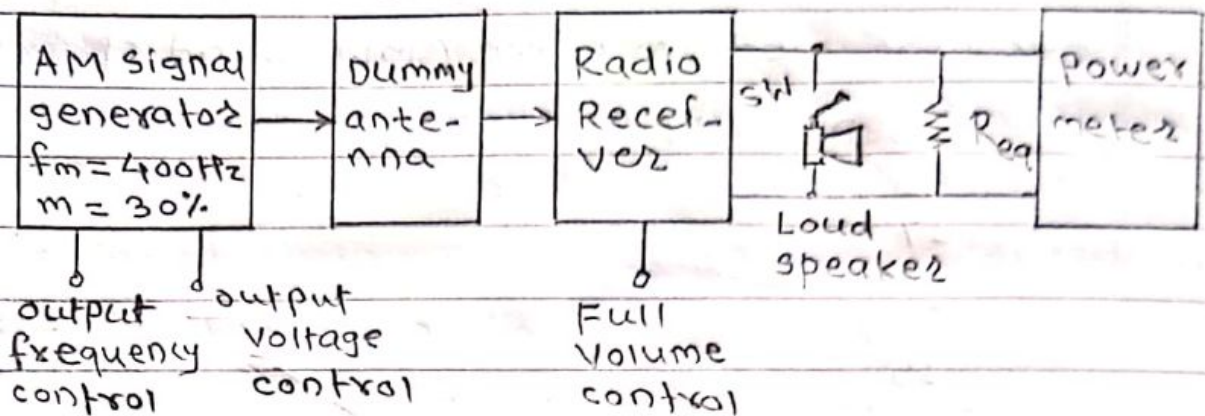

Fig. 2 Setup to measure sensitivity & selectivity

A standard input AM signal at 30% modulation and 400 Hz modulating frequency is applied to the receiver through dummy antenna. The input voltage required to obtain a standard output power of 50 mW is measured. This gives the sensitivity of the receiver. The measurement is carried out with the full volume control knob at its full volume position.

Procedure to measure sensitivity

- (1) connect the setup as shown in Fig. 2.
- (2) Adjust $f_m = 400 \text{ Hz}$, $m = 30\%$ on the AM signal generator.
- (3) Adjust the carrier frequency of AM at 530 kHz. Then adjust the output voltage of the signal

generator to get a standard output of 50mW across the resistance R_{eq} . Measure the corresponding input voltage.

(4) Repeat step-3 for various values of carrier frequency from 530 kHz to 1650 kHz.

(5) Plot the graph of carrier frequency on x-axis versus receiver input on y-axis. This is the sensitivity curve.

The observation table for sensitivity measurement is shown in the following table.

Sr. No.	Carrier Frequency	Input voltage to get the standard output
1	530 kHz	---
2	600 kHz	---
1	1	1
1	1	1
1	1	1
10	1650 kHz	---

(II) Selectivity

The selectivity of a receiver is its ability to reject unwanted signals. The selectivity is expressed as curve as shown in below Fig. 3. It shows that the receiver offers a minimum rejection at 950 kHz i.e. at tuned frequency, but the reje-

ction increases as the input signal frequency deviates on both the sides of 950 kHz. The selectivity of a superheterodyne receiver is determined by the frequency response characteristics of the IF amplifier. The response of the mixer and RF amplifier stages also play a small but significant role. The selectivity decides the adjacent channel rejection of a receiver.

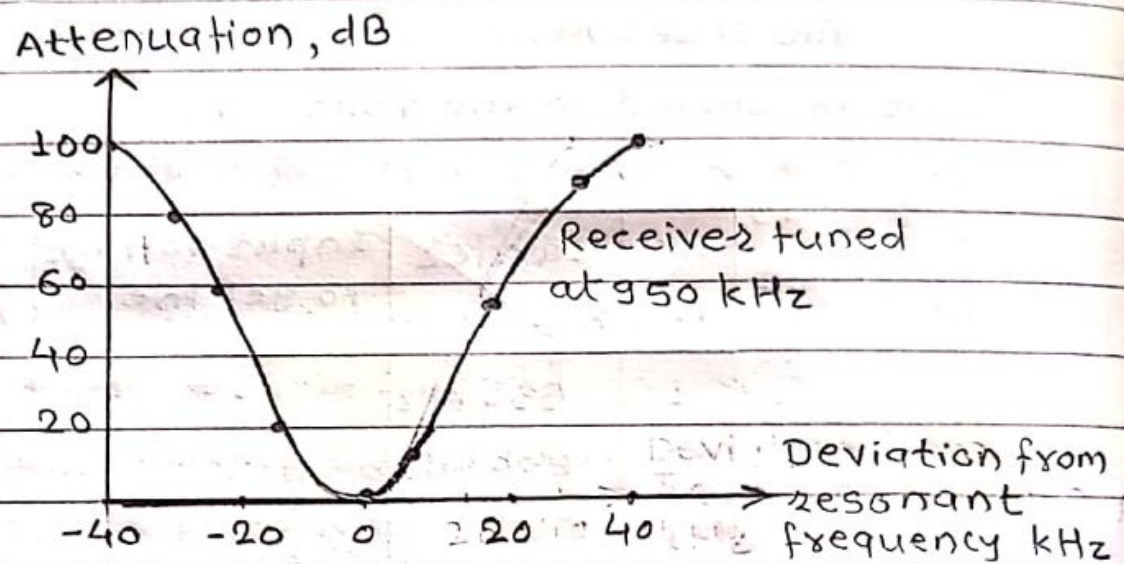

Fig. 3 Typical selectivity curve

Selectivity Measurement

The conditions for measurement of selectivity are same as those for sensitivity measurements. Referring Fig. 2 the receiver is tuned to 950 kHz, and the input is adjusted to get standard output by adjusting the generator output frequency to 950 kHz. Now the generator output frequency is deviated above and below 950 kHz in suitable

steps. Every time the generator output voltage is adjusted and noted down to get a standard 50 mw receiver output power. The attenuation is calculated and plotted as shown in Fig. 3.

The observation table for the attenuation measurement is given below.

Sr. No.	Deviation from the resonant frequency (kHz)	Attenuation dB
1	2 kHz	-
2	4 kHz	-
!	!	-
!	!	-

< III > Fidelity

The fidelity is the ability of a receiver to reproduce all the modulating frequencies equally. The fidelity basically depends on the frequency response of the AF amplifier. The typical fidelity curve is shown in Fig. 4.

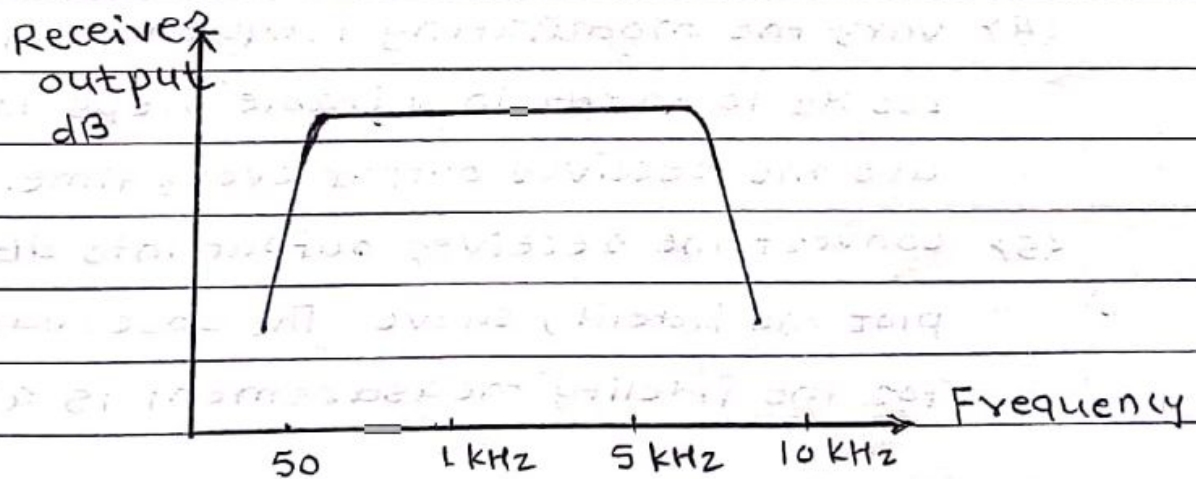

Fig 4 Fidelity curve

High fidelity is essential in order to reproduce a good quality music faithfully i.e. without introducing any distortion. For this it is essential to have a flat frequency response over a wide range of audio frequencies.

The fidelity curve for a receiver shown in Fig. 4 is basically the frequency response of the AF amplifier stage in the receiver. The procedure to plot the fidelity curve is as follows:

Procedure to plot the fidelity curve:

- (1) connect the setup as shown in Fig. 2.
- (2) Adjust $m = 30\%$ and carrier frequency $f_c = 1000 \text{ kHz}$. Keep this frequency constant throughout the fidelity measurement.
- (3) Now adjust the modulating frequency $f_m = 1 \text{ kHz}$ and adjust the output voltage to get the maximum undistorted output. Keep this input voltage constant throughout the experiment.
- (4) Vary the modulating frequency f_m from 100 Hz to 10 kHz in suitable steps and measure the receiver output every time.
- (5) Convert the receiver output into dB and plot the fidelity curve. The observation table for the fidelity measurement is as follows:

Observation table for fidelity measurement

Sr. No.	Modulating frequency f_m	Receiver output dB
1	100 kHz	--
2	1	--
1	1	--
1	1	--
1	1	--
10	10 kHz	--